



20M



A concentration of power in such a small space?

20M industrial air motors

- Power: 160W reversible models; 200W non-reversible models
- Idle speed: from 40 up to 20.000 r.p.m.

Fiam

PEOPLE AND SOLUTIONS

20M industrial air motors

20M industrial air motors: solutions for every need

Compact, performing, light, reliable: the 20M industrial air motors represent the **ideal solution for many applications**. Available in non-reversible or reversible version, they can advantageously be used for mixing liquid substances, moving, drilling, milling, grinding, sawing and so on.

Therefore they can be **installed** on conveyor belts, machine tools, automatic feed devices and on bottling machines, foodstuff processing, packing, manufacturing of buttons and glass objects, on textiles machines, bookbinding, plastics, paint-spraying, assembly, drilling, threading, grinding, stud driving, etc.

The air motors 20M of 200 Watt in power are **extremely sturdy** and they guarantee constant performances also in difficult working conditions.

Compact and light, they are easy to use in every situation; moreover, thanks to their extremely **reduced dimensions**, they are a quarter of the equivalent electric motor.

These motors are very versatile; they can be **customized for particular** applications requiring specific motor design and construction.

Fiam is able to develop these solutions with **customized motors** to satisfy customer's specific needs: a great competitive advantage, especially when the motor has to be integrated within a certain type of equipment or within a particular type of tool.

Be demanding

Reliability

Long lifetime of the components thanks to careful design and to quality of the productive process which results in less maintenance and repair costs

Innovative design principles warranty an **immediate and always guaranteed start**, also at low air feed pressure, and a **flexible functioning without vibrations**

High quality two ball bearings reductions allow to use the motors with elevated radial and/or axial loads

Weight and dimension are extremely reduced to optimize the installation also in small machines

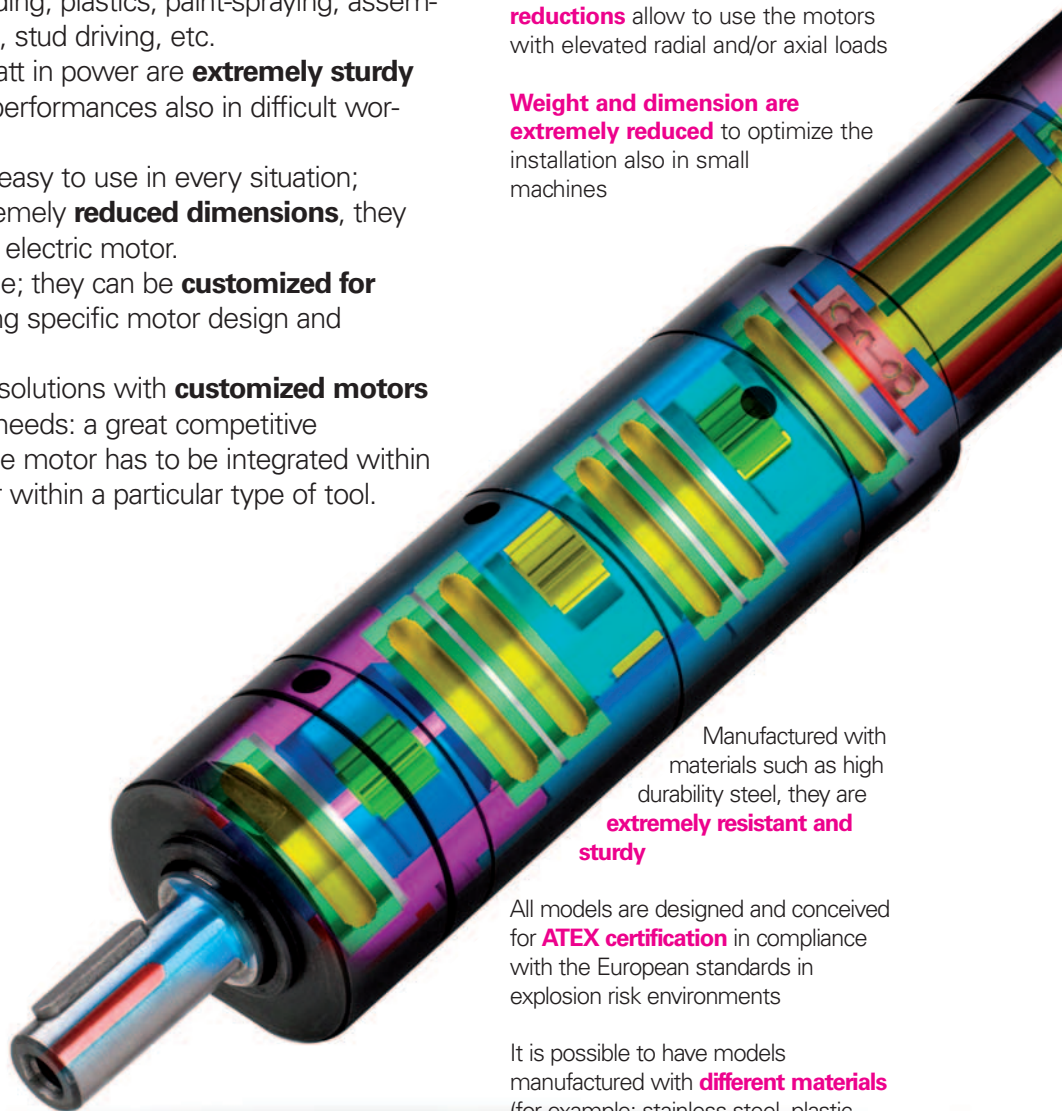

Manufactured with materials such as high durability steel, they are **extremely resistant and sturdy**

All models are designed and conceived for **ATEX certification** in compliance with the European standards in explosion risk environments

It is possible to have models manufactured with **different materials** (for example: stainless steel, plastic, special treatments) for maximum reliability in every situation

Don't be satisfied with the maximum

Perfection for your solutions

Naturally innovative

Productivity

Ergonomics

Ecology

Considerable increase of the efficiency of the tightening cycle thanks to innovative systems

Optimization of the tool performances in regard to ergonomics and operator safety

Innovative systems designed paying even more attention with respect to environment and of its safeguard

The materials and the heat treatments on the reduction gears guarantee **maximum output, long lifetime and reduced noise level**

The motors are conceived to **reduce noise level in working environment**, thanks to the use of oil separator filters for conveying the air exhaust

The advanced technological design of the **air motor** permits very high decrease of **compressed air consumption**, without affecting motor performance

The motors are **completely modular** for faster maintenance and replacement of the spare parts in case of wear

In compliance with European standard, Fiam motors are conceived for ATEX certification (explosion risk environment); they provide the **maximum operator safety** mainly where inflammable or explosive substances are present, and in damp or high temperature environment

All the components are **easy to dispose of** because they are built using recyclable materials; therefore they do not represent any danger for environmental pollution

The use of many common components **favours the supplying and the management of the spare parts**

They haven't **any risk of overheating** also in difficult heavy duty conditions, repetitive stops/starts or inversion of rotation

The use of oil separator filters for conveying the air exhaust guarantees the **absence of oil fog into the working environment**

It's possible to obtain many **customized models**: with different output shafts (example: tapered, morse taper, threaded, different diameters, with gear), with different external materials and dimensions. For all models a **wide range of accessories** is available

These air motors are equipped with a **silencing system** that reduces the noise levels

All Fiam products are supplied with **eco-friendly packaging**

These motors permit **an easy adjustment** of the torque, speed and rotation direction through simple control methods

In **reversible motors** the reverse of rotation takes place in milliseconds

The newly conceived air motor ensures **high performances also at low air feed pressure**

They are available also in **versions with low revolutions**, particularly suitable for different applications: mixing, positioning, moving, etc.

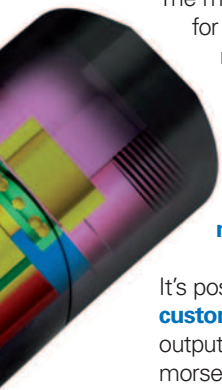

Features and performances of Fiam air motors

Performances of an air motor depend on the dynamic air inlet pressure measured at the intake of air motor; therefore by simply adjusting the air supply, using the techniques of throttling or pressure regulation, we can obtain the characteristic linear output torque/speed relationship. The performance data of the 20M motors is valid for an air supply pressure of 6,3 bar (ISO 2787).

The main features of an air motor are:

- **Power** in Watt
- **Speed at point of maximum power**, rpm
- **Torque at maximum power**, Nm
- **Starting torque**, Nm
- **Idle speed**, rpm
- **Air consumption at maximum power**, l/s

The power

The power in Watt that an air motor produces is simply the product of torque and speed. Every motor produces a characteristic power curve, with maximum power occurring at around 50% of the idle speed.

The torque produced at this point is referred to as torque at maximum power.

The power of an air motor is obtained with the following formula:

$$P = (\pi \times M \times n) / 30$$

Legend

P = Power in Watt

M = Torque in Nm

n = Speed (rpm)

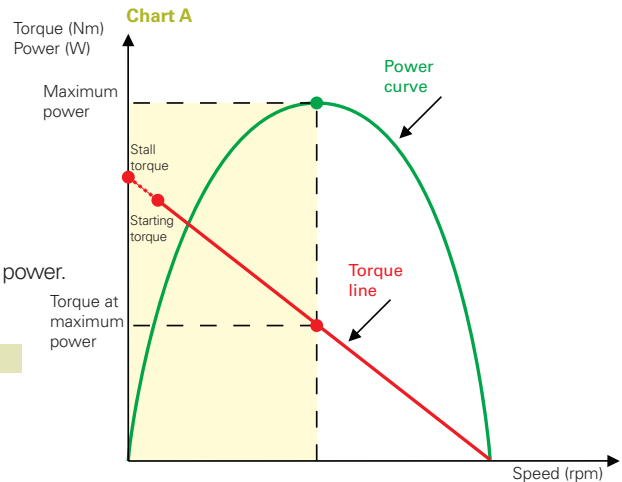

The speed

Every air motor has an idle speed which is obtained by inserting one or more reduction gears - depending on the reduction ratio - between the driving unit and the output shaft.

At the maximum speed ("idle speed") the torque (turning moment) as taken at the output shaft, is nil, while, as load is applied, the speed will decrease inversely proportional to the torque (see chart A).

Torque at maximum power, starting torque and stall torque

The **torque at maximum power** is obtained at around 50% of idle speed that corresponds to maximum power of the motor (see chart A).

The **starting torque** is the torque that the motor gives to the output shaft under load and when you feed full air pressure into it (see chart A).

The **stall torque** is the torque that the motor gives at the output shaft when it is blocked during its rotation.

The stall torque is approximately double respect to the torque at maximum power.

How to choose an air motor

When selecting a motor, it is important to identify the '**working point**' appropriate for your application.

This 'working point' is given by under load operating speed required by motor and by torque necessary at that speed.

FOR EXAMPLE

A non-reversible solution to operate at 1350 rpm and at 1,25 Nm is required.

It is necessary to **consider the performance curves of every model** and to identify the '**working point**' that for this example corresponds to the yellow coupon in the chart here beside. The choice of the motor will be the one where the 'working point' is the nearest to the torque at the maximum power (indicated by the red coupon on the chart).

The motor to be chosen is therefore model: **20M260D-D10**.

If necessary, one of the methods to reach your 'working point' **is to act on the feed pressure** by applying the coefficients of variation of the performances parameters of the motor (see chart 1 on the page here beside).

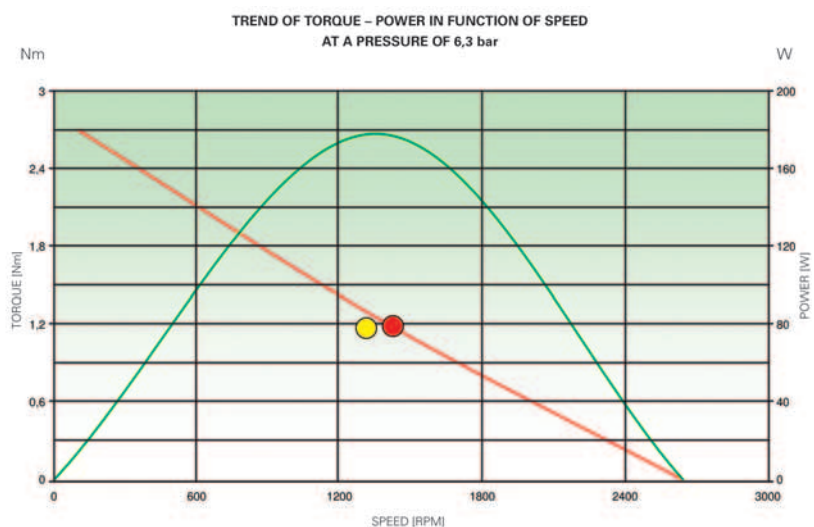

Regulation of the performances features of the motor

The performances features can be modified with continuity by means of a pressure or throttling regulator that reduces or increases the air quantity in the motor.

Consequently there is a decrease or an increase of the power, torque and speed values.

To calculate them the coefficients in chart 1 must be used.

There are **two methods to adjust** motor's performances:

- With an **air flow governor** installed before the air inlet coupling the **control of the stall torque is obtained**
- With an **air flow governor** installed on the air exhaust coupling **the starting torque is maintained and the motor's speed is adjusted**

Chart 1

Pressure (bar)	Power	Torque	Speed	Consumption
7	1,21	1,17	1,03	1,15
6	1,00	1,00	1,00	1,00
5	0,77	0,83	0,95	0,82
4	0,55	0,67	0,87	0,65
3	0,37	0,50	0,74	0,47

Coefficients of variation of the performances parameters of an air motor in function of the feed pressure.

Air feed and its consumption

The air consumption of the air motor is at **maximum** when the motor turns at **idle speed**.

To obtain the performances on catalogue it is necessary to guarantee a **correct air feeding** and air exhaust and to **follow these indications**:

- Respect always **recommended air hose bore** for air feed and exhaust hoses
- It is advisable that the **diameter of the exhaust hose** is greater than the air supply hose.
In the case of reversible motor, two inlets have to permit alternatively the entrance and the exhaust of the air i.e. that the inlet which is not used is left free so that the exhaust air can flow
- **Avoid joints and quick couplings**; they reduce the air flow
- It is always advisable to **use a FRL group** (filter, pressure regulator, lubricator) appropriate to motor consumption
- It is advisable to connect the exhaust hoses to **oil separator filter with built-in silencing system** that **further reduces the noise** level and **lubricates the motor** with no emission of air exhaust in working environment, allowing oil to be collected and reused.

Pneumatic circuit scheme (feed control of the motor)

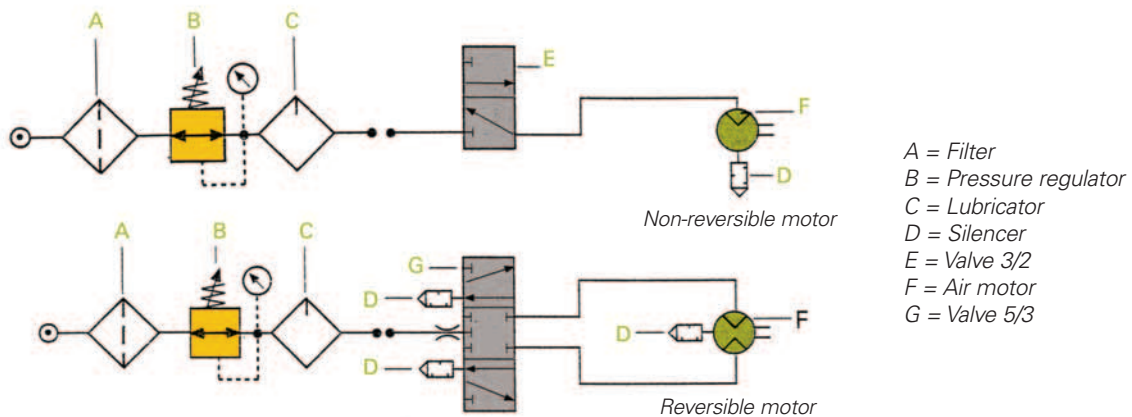

Figure 1

Models with smooth output shaft

(\varnothing 10 mm with key UNI 6604 form A)



Non-reversible models

Type of motor		Reversibility	Power	Speed at the max power		Torque at the max power		Starting Torque		Idle speed	Air consumption at the max power		Weight
Model	Code	Type	Watt	rpm	Nm	in lb	Nm	in lb	rpm	l/s	Kg	lb	
20M2000D-D10	183311200	↻	200	11000	0,20	1,77	0,30	2,66	20000	5,3	0,40	0,88	
20M430D-D10	183311400	↻↻	200	2030	0,80	7,08	1,35	11,95	4300	5,3	0,40	0,88	
20M260D-D10	183311210	↻↻↻	200	1350	1,25	11,06	2,10	18,59	2600	5,3	0,40	0,88	
20M105D-D10	183312100	↻↻↻↻	200	530	3,10	27,44	5,40	47,79	1050	5,3	0,54	1,19	
20M60D-D10	183312600	↻↻↻↻↻	200	305	5,30*	46,91*	8,80*	77,88*	600	5,3	0,54	1,19	

Reversible models

Model	Code	Type	Watt	rpm	Nm	in lb	Nm	in lb	rpm	l/s	Kg	lb
20M1650R-D10	183511100	↻	160	9000	0,15	1,33	0,25	2,21	16500	5,0	0,40	0,88
20M400R-D10	183511300	↻↻	160	1950	0,80	7,08	1,20	10,62	4000	5,0	0,40	0,88
20M250R-D10	183511200	↻↻↻	160	1330	1,40	12,39	2,20	19,47	2500	5,0	0,40	0,88
20M100R-D10	183512900	↻↻↻↻	160	550	3,05	26,99	4,80	42,48	1000	5,0	0,54	1,19
20M58R-D10	183512500	↻↻↻↻↻	160	300	5,70*	50,45*	7,50*	66,38*	580	5,0	0,54	1,19

*The maximum torque permitted, for continuous use, is from 4 to 5 Nm

Models with threaded output shaft

(3/8x24 UNF)

Ideal to use the motors in drilling, burring, etc. operations.
Available only for version with clockwise rotation.



Non-reversible models

Type of motor		Reversibility	Power	Speed at the max power		Torque at the max power		Starting Torque		Idle speed	Air consumption at the max power		Weight
Model	Code	Type	Watt	rpm	Nm	in lb	Nm	in lb	rpm	l/s	Kg	lb	
20M2000D-3/8X24UNF	183341200	↻	200	11000	0,20	1,77	0,30	2,66	20000	5,3	0,40	0,88	
20M430D-3/8X24UNF	183341400	↻↻	200	2030	0,80	7,08	1,35	11,95	4300	5,3	0,40	0,88	
20M260D-3/8X24UNF	183341210	↻↻↻	200	1350	1,25	11,06	2,10	18,59	2600	5,3	0,40	0,88	
20M105D-3/8X24UNF	183342100	↻↻↻↻	200	530	3,10	27,44	5,40	47,79	1050	5,3	0,54	1,19	
20M60D-3/8X24UNF	183342600	↻↻↻↻↻	200	305	5,30*	46,91*	8,80*	77,88*	600	5,3	0,54	1,19	

*The maximum torque permitted, for continuous use, is from 4 to 5 Nm

Models with collet shaft

(ER11 – collet chuck included)

They are indispensable when the use of collets reduces the dimensions of encumbrance of the head of the drilling unit thus ensuring more accuracy in drilling. Available only for version with clockwise rotation. The collet is excluded, see Accessories available upon request.



Non-reversible models

Type of motor		Reversibility	Power	Speed at the max power	Torque at the max power		Starting Torque		Idle speed	Air consumption at the max power	Weight	
Model	Code	Type	Watt	rpm	Nm	in lb	Nm	in lb	rpm	l/s	Kg	lb
20M2000D-ER11	183331200	↻	200	11000	0,20	1.77	0,30	2.66	20000	5,3	0,40	0.88
20M430D-ER11	183331400	↻↻	200	2030	0,80	7.08	1,35	11.95	4300	5,3	0,40	0.88
20M260D-ER11	183331210	↻↻↻	200	1350	1,25	11.06	2,10	18.59	2600	5,3	0,40	0.88
20M105D-ER11	183332100	↻↻↻↻	200	530	3,10	27.44	5,40	47.79	1050	5,3	0,54	1.19
20M60D-ER11	183332600	↻↻↻↻↻	200	305	5,30*	46.91*	8,80*	77.88*	600	5,3	0,54	1.19

*The maximum torque permitted, for continuous use, is from 4 to 5 Nm

Legend

20 = Power of the motor in Watt/10 • M = Air motor • 2000 = revolutions/10 • D = Right (non-reversible) • R = Reversible • -D10 = Smooth output shaft \varnothing 10 mm with key UNI 6604 form A • -3/8 x 24UNF = Threaded output shaft 3/8x 24UNF • ER11 = Collet shaft ER11

Legend

↻↻↻↻↻ reversibility: right and left

↻↻↻↻↻ reversibility: right (clockwise)
↻↻↻↻↻ the direction in which the output shaft turns in considered to be in function of the delivery air input

- The figures shown are measured at a pressure of 6,3 bar (ISO 2787), the recommended operating pressure
- Working air pressure: max 7 bar.
- The code number must be used when ordering.

The above figures should be used as a guide only and could be changed without notice. For all further details, please apply to the **Fiam Technical Consultancy Service**

N.B. The noise level in the motors is generated by the air exhaust. The level increases as the speed increases and it is at the maximum when the motor rotates at idle speed. All the motors are supplied with a threaded connection which is needed to connect, with a suitable coupling, a hose conveyor in order to take the exhaust air away from the working environment. Fiam recommends to convey the exhaust air to an oil separator filter with built-in silencing system which also permits to give an adequate lubrication to the motors without polluting the working environment.

*The maximum torque permitted, for continuous use, is from 4 to 5 Nm

Other technical features

Model	Air inlet	Recommended hose bore	Output shaft
20M...D/R-D10	1/8" gas	\varnothing 6 mm	Smooth shaft \varnothing 10 mm with key UNI 6604 Form A
20M...D-3/8x24UNF	1/8" gas	\varnothing 6 mm	Threaded output shaft 3/8x24UNF
20M...D-ER11	1/8" gas	\varnothing 6 mm	Collet shaft ER11

Models available upon request

- Models with smooth output shaft \varnothing 13 mm
- Models with different output shafts: tapered, Morse taper, with gear, shafts with different diameter
- Models with only anti clockwise rotation (except models with threaded shaft)
- Models with flanged sleeves
- Special models customised for client
- Models with housing and output shaft made of different materials (e.g.: stainless steel, plastic, ...)
- Models with ATEX certification

Models with low rotations with smooth output shaft

(ø 10 mm with key UNI 6604 form A)
maximum torque permitted: 4-5 Nm

These motors are suitable for many applications: mixing, moving, components positioning, various movements, etc. and they are used in many industrial applications.

The leading technical factor for the choice is the low rotation speed; it isn't the working torque as for standard industrial motors.

The use of these motors is particular. **They must not be used according to torque range**, otherwise on stall they could reach very high torques and compromise the inner kinematic gears of the motor. Therefore the load must be regulated in such way that the torque does not exceed the 4-5 Nm.



Non-reversible models

Type of motor	Model	Code	Reversibility Type	Power Watt	Idle speed rpm	Air consumption l/s	Weight Kg	Weight lb
	20M35D-D10	183312300	↻	200	350	5,3	0,54	1.19
	20M14D-D10	183313100	↻↻	200	140	5,3	0,70	1.54
	20M8D-D10	183313800	↻↻↻	200	80	5,3	0,70	1.54
	20M5D-D10	183313500	↻↻↻↻	200	50	5,3	0,70	1.54

Reversible models

Model	Code	Type	Watt	rpm	l/s	Kg	lb
20M30R-D10	183512300	↻	160	300	5,0	0,54	1.19
20M13R-D10	183513100	↻↻	160	130	5,0	0,70	1.54
20M7R-D10	183513800	↻↻↻	160	70	5,0	0,70	1.54
20M4R-D10	183513500	↻↻↻↻	160	40	5,0	0,70	1.54

Legend

20 = Power of the motor in Watt/10 • M = Air motor • 35 = revolutions/10 • D = Right (non-reversible) • R = Reversible • D10 = Smooth output shaft ø 10 mm with key UNI 6604 form A

Legend

↻ reversibility: right and left

↻ reversibility: right (clockwise)
↻ the direction in which the output shaft turns in considered to be in function of the delivery air input

- The figures shown are measured at a pressure of 6,3 bar (ISO 2787), the recommended operating pressure
- Working air pressure: max 7 bar.
- The code number must be used when ordering.

The above figures should be used as a guide only and could be changed without notice. For all further details, please apply to the Fiam Technical Consultancy Service.

N.B. The noise level in the motors is generated by the air exhaust. The level increases as the speed increases and it is at the maximum when the motor rotates at idle speed. All the motors are supplied with a threaded connection which is needed to connect, with a suitable coupling, a hose conveyor in order to take the exhaust air away from the working environment. Fiam recommends to convey the exhaust air to an oil separator filter with built-in silencing system which also permits to give an adequate lubrication to the motors without polluting the working environment.

Other technical features

Model	Air inlet	Recommended hose bore	Output shaft
20M...D/R	1/8" gas	Ø 6 mm	Smooth shaft ø 10mm with key UNI 6604 Form A

Models available upon request

- Models with rotations lower than those indicated in chart
- Models with different output shafts: threaded 3/8 - 24 UNF, tapered, Morse taper, with gear, shafts with different diameter
- Models with only anti clockwise rotation
- Models with flanged sleeves
- Special models customised for client
- Models with housing and output shaft made of different materials (e.g.: stainless steel, plastic,...)
- Models with ATEX certification

Models with smooth output shaft

(\varnothing 10 mm with key UNI 6604 form A)

Dimensions (mm)

Model	L
20M2000D - D10	103
20M430D - D10	103
20M260D - D10	103
20M105D - D10	134
20M60D - D10	134
20M1650R - D10	103
20M400R - D10	103
20M250R - D10	103
20M100R - D10	134
20M58R - D10	134

Non Reversible

Reversible

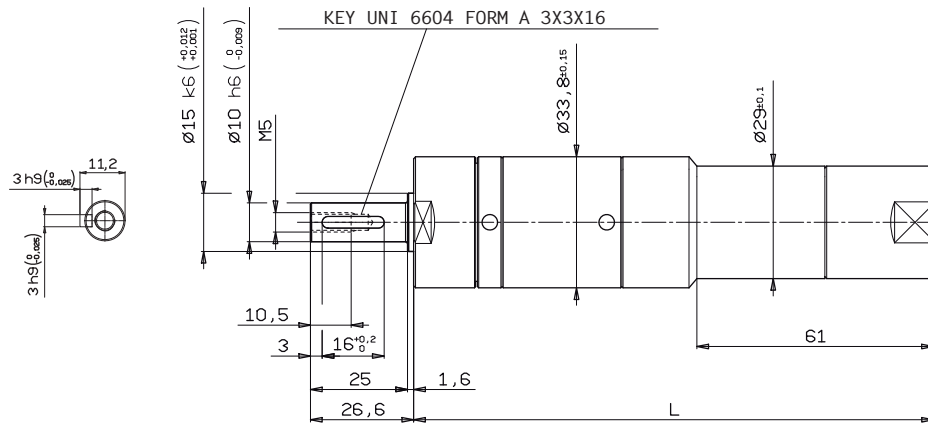
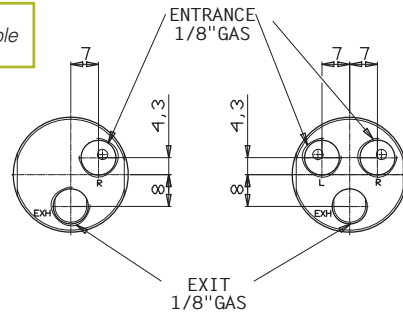

Models with threaded output shaft

(3/8x24UNF)

Dimensions (mm)

Model	L
20M2000D-3/8x24UNF	103
20M430D-3/8x24UNF	103
20M260D-3/8x24UNF	103
20M105D-3/8x24UNF	134
20M60D-3/8x24UNF	134

Non Reversible

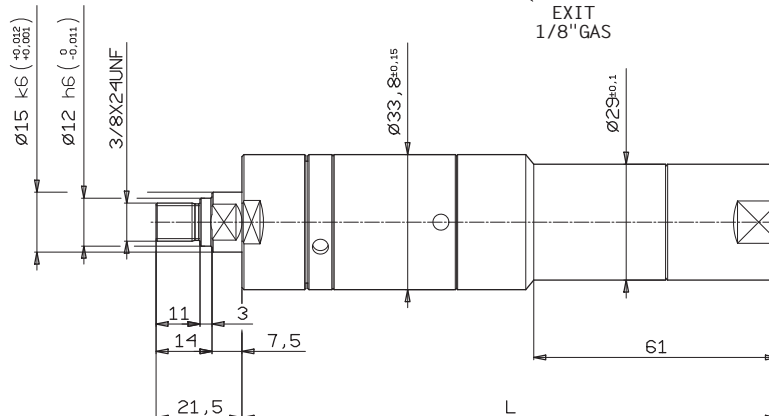
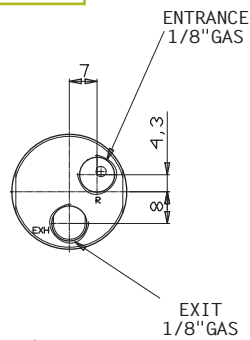

Models with collet shaft

(ER11)

Dimensions (mm)

Model	L
20M2000D-ER11	103
20M430D-ER11	103
20M260D-ER11	103
20M105D-ER11	134
20M60D-ER11	134

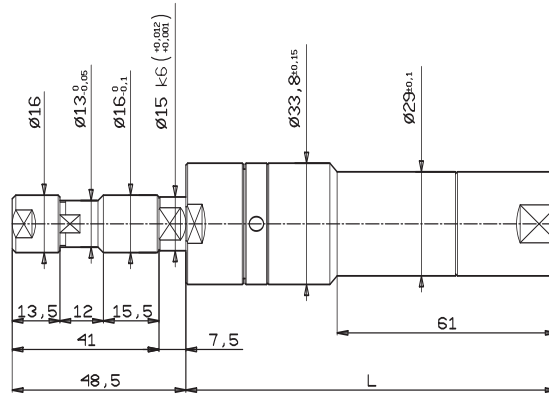
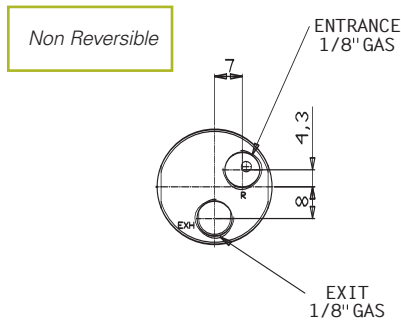

Models with low rotations with smooth output shaft

(\varnothing 10 mm with key UNI 6604 form A)

Dimensions (mm)

Model	L
20M35D-D10	134
20M14D-D10	165
20M8D-D10	165
20M5D-D10	165
20M30R-D10	134
20M13R-D10	165
20M7R-D10	165
20M4R-D10	165

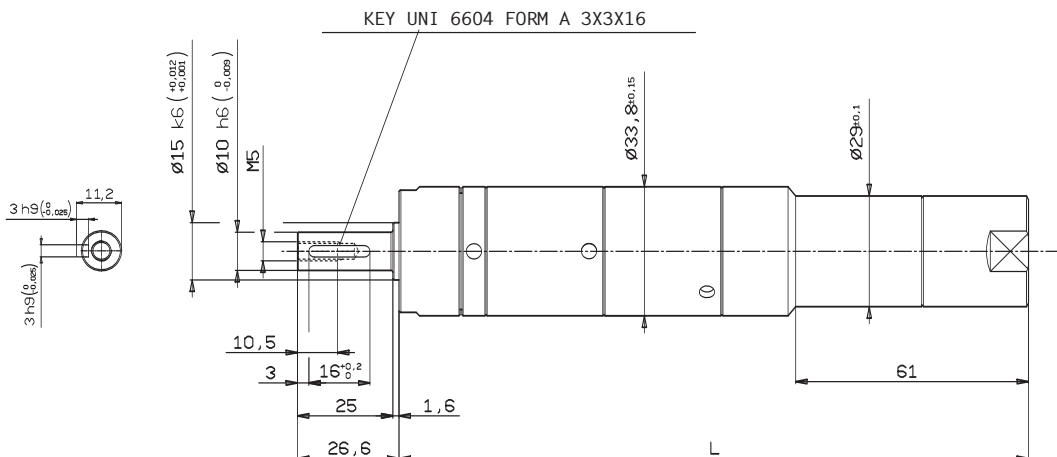
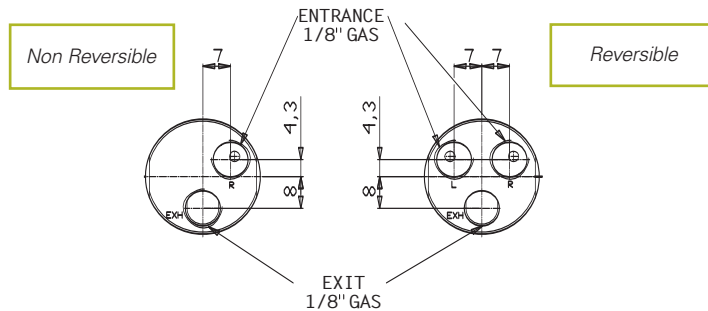

Performances diagrams of torque, power and speed

The diagrams show the curves for torque and power in function of number of revolutions: torque — power —
Trend of torque - power in function of speed (at a pressure of 6,3 bar)

Non-reversible models

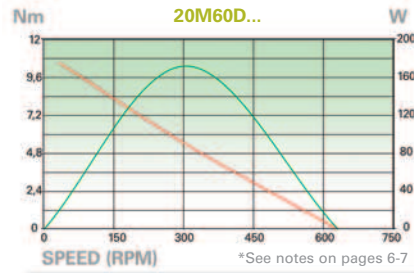
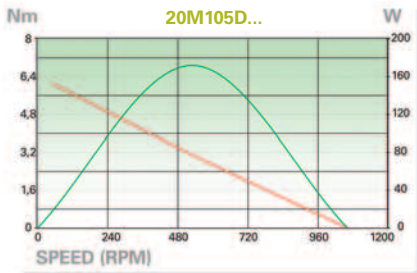
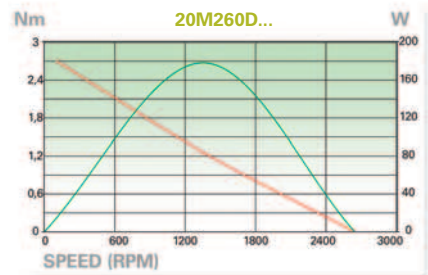
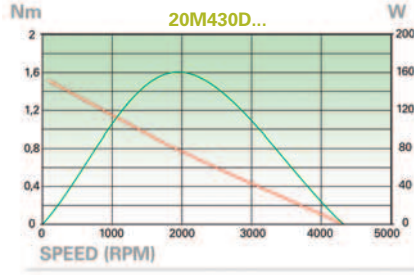
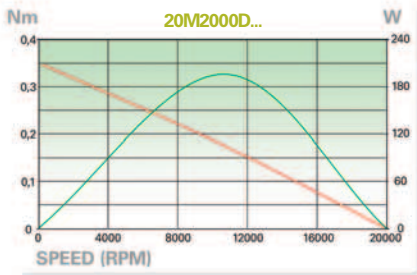

Reversible models

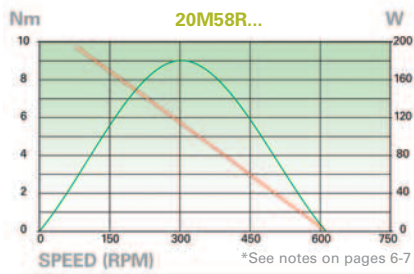
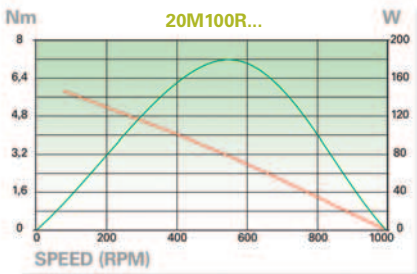
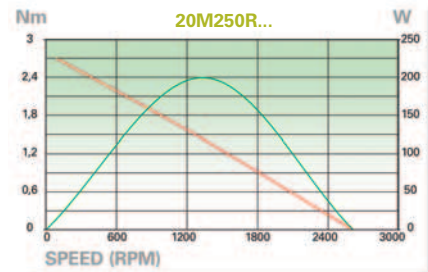
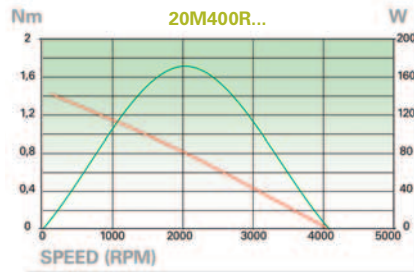
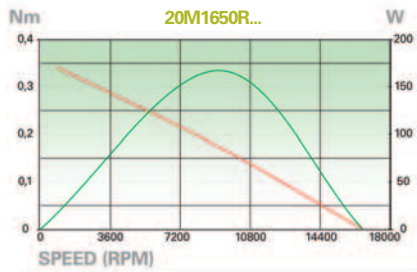

Accessories

• Flange bracket

Recommended to fix the motors onto machines/units

Description	Code
Flange bracket	684011001

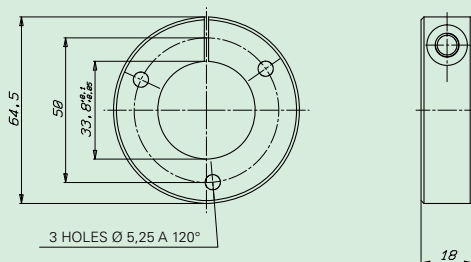

Accessories for the use of air motors in drilling operations

• To use Fiam motors in drilling, burring, etc. operations it is necessary to order a motor with threaded output shaft 3/8" x 24 UNF (available only for motor with right hand rotation).

• Keyed chucks

Sturdy chucks equipped with locking key to block the bit of the drill. The dimensions are expressed in millimeters (mm)

Chuck capacity (mm)	Drive type	Code
0 + 6	3/8 x 24 UNF	650381006
0 + 8	3/8 x 24 UNF	650381008

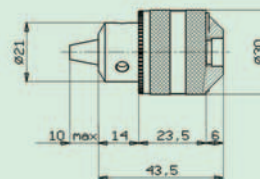

Chuck capacity (mm)	Drive type	Code
1 + 10	3/8 x 24 UNF	650381010

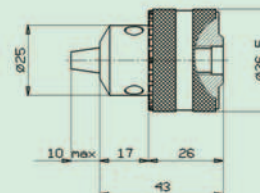

• Collet chucks

The use of collets on motors with collet chuck permits to reduce the dimensions of encumbrance of the head of the drilling unit and to obtain the better accuracy in drilling.

Collet chuck	Drive type	Code
ER 11	3/8x24 UNF	660449011

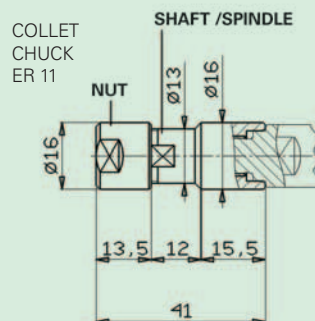

• Collets

They are to be chosen according to the diameter of the bit

* The locking capacity of the collet is referred to the diameter of the male shank of the bit

ER 11

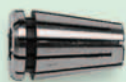

Collets ER11

Capacity ϕ (mm)*	Code
1	660431010
1,5	660431015
2	660431020
2,5-3/32"	660431025
3	660431030
3,5-1/8"	660431035
4	660431040
4,5	660431045
5-3/16"	660431050
5,5	660431055
6	660431060
6,5-1/4"	660431065
7	660431070

Locking capacity of the collets

0,5 mm

Fiam

PEOPLE AND SOLUTIONS

Fiam Utensili Pneumatici Spa
 Viale Crispi 123 - 36100 Vicenza - Italy
 Tel. +39.0444.385000 - Fax +39.0444.385002
 customerservice@fiamairtools.com
 www.fiamairtools.com

Environmental Management
System Certificate



Quality Management
System Certificate

